

The FastCamera13 USB2.0 is a high-speed megapixel digital camera system, based on a CMOS imager with an electronic shutter. This camera has a high-speed, scalable, integrated FPGA and memory subsystem which enable stand-alone high speed in-camera image processing. Also the firmware provides in-camera ring buffer memory of up to one GB which is software compatible by a user friendly windows based GUI. Trigger and free running modes are supported. Also the USB2.0 interface can be used simultaneously as a

FastCamera13 Key Features:

- The Fastcamera13 is a 1280H x 1024V (megapixel) CMOS digital image sensor
- 1280H x 1024V image resolution
- 12-micron-square active-pixel photodiodes
- 500 frames per second, progressive-scan at full resolution, frame rate can go up to 500,000 fps at 1 x 1280 pixels
- Monochrome or color (Bayer Pattern)
- Ten (10) parallel output ports
- Photobit® TrueColor™ Image Fidelity
- On-chip TrueBit® Noise Cancellation
- On-chip 10-bit analog-to-digital converters
- FPGA and memory-based configurable interface formats and onboard processing
- Supported by a full range of software tools, including fully optimized microcoded signal and image processing libraries
- Binning in order to achieve increased sensitivity at full frame rates
- Optional additional DDRAM and increased FPGA size for additional processing capability
- Trigger-able global electronic shutter (sync/async modes)
- C mount lens (F with adaptor)

SMART CAMERAS FOR IMAGING



Modes of operation:

The system supports a wide range of custom user selected ROIs and operating modes. For example, full resolution 1280x1024 frames at 500 fps with smaller ROI speeds of up to 100x100 pixels at 5000 fps , 1 X 1280 pixels at 500,000 fps.

The system can be provided with dedicated software to perform gauging, tooling and pattern matching in the camera. Thus providing a stand-alone system for real-time, flexible measurement and pattern analysis applications.

Applications:

The FastCamera13 is a complete system for capturing complex high-speed events for traditional machine vision applications as well as high speed imaging events that need analysis through slow motion playback. The system has easy configuration with plug and play features that offer expanded recording time of up to several seconds at full rate of 660 MB/sec using on-board memory. Also using available compression IP, a user can use the USB2.0 for lossless or lossy increase in memory capacity on-camera or lossy real-time data collection to the computer .

This intelligent camera system is optimal for production line machine inspection, production line fast real-time event detection, laboratory microscopy, corporate and military research.

FastCamera13 USB2.0

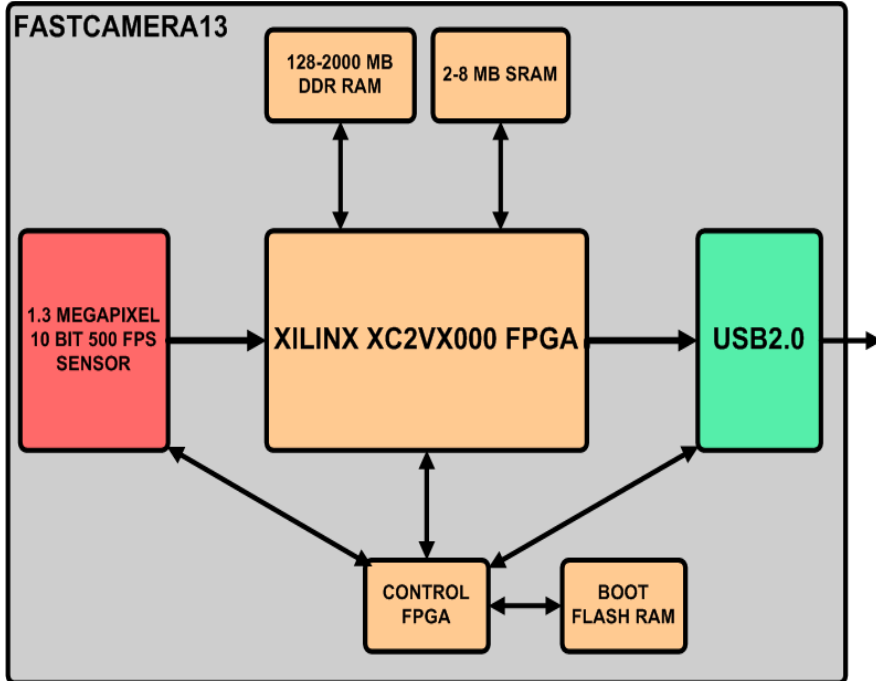

OUTPUT SPECIFICATIONS

- USB2.0 for output from memory or display

PHYSICAL SPECIFICATIONS

- Power supply +5 Volts
- 12 Pin Hirose Power Connector
- External Trigger In and Out (sync/async modes)
- 0 to 50 Degree C operating
- Weight < 600 grams

PARTIAL SCAN FRAME RATES 8 BIT PIXELS

- In every case row size is 1280 pixels
- 1 row in frame: ~500,000 frames/ sec.
- 2 rows in frame: ~250,000 frames/ sec.
- 10 rows in frame: ~50,000 frames/ sec.
- 100 rows in frame: ~5,000 frames/ sec.
- 256 rows in frame: ~2,000 frames/ sec.
- 512 rows in frame: ~1,000 frames/ sec.
- 1,024 rows in frame: ~500 frames/ sec.

IMAGING SPECIFICATIONS

- 1280 x 1024 x 8 bits @ 500 fps (10 bits 400 fps)
- 15.36 mm x 12.29 mm active area
- 12-micron square active pixels
- 40% Fill Factor
- Monochrome or color (Bayer Pattern)
- On-chip Noise Cancellation
- Dynamic range 59 db
- Monochrome: 1000 bits per lux-second @ 550 nm
- Shutter 99.9% efficiency
- Noise 58 db (10 bit mode lowest sensor gain setting, nominal pixel of 512 counts)

IN-CAMERA PROCESSING OPTIONS

- Image storage up to 1600 full size frames at full speed (more for partial scanned images)
- Image averaging
- By pixel gain and offset calibration
- Programmable ROI (via serial port)
- Image sub-sampling
- Convolution filtering
- Binarization with dynamic threshold
- Lossless and lossy real-time compression at full speed using VHDL and Verilog compatible IP
- VHDL customizable processing

FPGA AND MEMORY OPTIONS

- FPGA size options from one to eight million gates
- 128-2000 MB 64-bit DDR memory at 266 Mhz
- 2-8 MB SRAM

CAMERA CONTROL INTERFACE

- USB2.0 for control, output from memory, or display

